

Storm Mixer



Series "WAE"

Epoxy Coated Compact Ring Body Static Mixer

Wafer Style In Line Static Mixers



Storm Mixer's wafer mixer is the perfect solution for larger wafer mixers when space and lay length are at a premium. Designed to fit between flanges, this compact static mixer provides excellent mixing and low cost in a space saving package.

With a wide range of options and styles available, Storm wafer style mixers can easily be adapted to meet the exacting needs of your specific application.

BENEFITS

- Compact Design.
- Low cost, economic design reduces static mixer costs.
- Broad chemical compatibility allows for a wide range of uses.
- Can be customized to fit your requirements.
- Low energy consumption.
- Easy installation.
- No maintenance.

FEATURES

- Easy installation in pipelines. Fits within the bolt circle of pipe flanges.
- Epoxy coated construction insures chemical compatibility with a wide range of chemicals.
- Unique design of mixing elements provide high levels of mixing in a short lay length.
- Adaptable to both liquid and gas stream applications.
- Available in standard and low pressure drop versions.

APPLICATIONS

- Chlorine
- Ammonia
- Flocculants
- Antiscalants
- Fluoride

Wafer mixers work best when mixing aqueous/ low viscosity chemicals. For viscous chemicals such as concentrated acids and polymers, a pipe style static mixer provides superior performance.

SPECIFICATIONS

Epoxy coated wafer mixers available in a range of sizes from 10" to 36". For smaller sizes we recommend stainless steel or PVC construction.

Available with a wide range of injectors and additive ports

MATERIALS OF CONSTRUCTION

Epoxy Coated Carbon Steel. Scotchkote™ 134 is a standard coating, however other coatings are available.

Scotchkote™ is a trademark of 3M Corporation.

MODEL NUMBER



WAE-20- S - _____

Carbon Steel Epoxy coated
Wafer Mixer Prefix

Custom number to designate special
configurations, ports, and injectors

Wafer Mixer Nominal Diameter (in) For 125/150# flanges	
Nominal Dia.	Code
10	10
12	12
14	14
16	16
18	18
20	20
22	22
24	24
36	36
Other sizes are available.	
For smaller size, we recommend the use of stainless steel.	

Aspect	
Low dP	L
Standard	S
High Shear	H

Example of a model number would be “WAE-12-S”.
Any model that requires custom features (such as different sizes/
types/quantities of ports, injectors, etc.) that are not listed will be given
a custom model number such as “WAE<number>”.

For further sizing information see the www.stormmix.com website.

Storm Epoxy Coated Carbon Steel Wafer Mixer “TYPICAL SPECIFICATION”

Storm Epoxy Coated Carbon Steel Wafer Static Mixer

The mixer shall be a wafer style mixer. The compact ring body shall be constructed from epoxy coated carbon steel. Coating shall be Scotchkote 134

All chemical injection should occur upstream of the mixing plate to ensure complete diffusion before mixing. The mixer shall provide for complete mixing with a maximum of 5% variation within 10 pipe diameters of the mixer.

The mixer shall be Model “WAE-____” manufactured by Storm Mixer or equal that has been preapproved by engineer before the bid.

Wafer Mixer Thickness ¹	
Mixer size nominal diameter (in)	Mixer thickness "D" (in)
10" - 12"	1/2"
14" - 36"	1"

¹ Thickness is for a wafer that does not have any integrated ports or injectors. Ports will add thickness to the wafer.

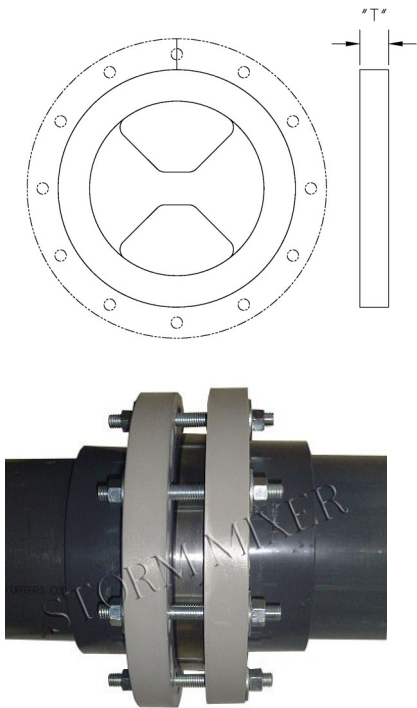

The Storm Wafer Mixer is designed to fit within the bolt circle of the flange. The wafer is installed between flanges using a set of (2) ring style gaskets.

Flow Recommendations & Pressure Drop Calculation

(Sized for 5 psi pressure drop at maximum flow)

In general a larger pressure drop improves mixing.

Nominal Dia	Flow Range Minimum/Maximum (gpm)		
	"L" Low dP Design	"S" Design	"H" High Shear Design
10	493 / 2461	370 / 1723	247 / 1231
12	699 / 3494	524 / 2446	350 / 1747
14	861 / 4304	646 / 3013	431 / 2152
16	1141 / 5701	856 / 3991	571 / 2851
18	1459 / 7294	1094 / 5106	730 / 3647
20	1817 / 9083	1363 / 6358	909 / 4542
22	2214 / 11068	1661 / 7748	1107 / 5534
24	2650 / 13250	1988 / 9275	1325 / 6625
30	4194 / 20970	3146 / 14679	2097 / 10485
36	6091 / 30455	4569 / 21319	3046 / 15228

The recommended flow range will ensure a maximum pressure drop of 5 psi for water based chemicals and ensure good mixing.

DISTRIBUTED BY:

Storm Mixer

Tel : 925 878 8392
 Fax: 925 575 8726
 email: info@stormmix.com

© 2013 Storm Mixer.

WAS Rev B

